



Application: Disinfection of cold and hot water of water supply system in order to prevent Legionella contamination.

Location of the installation: 300- bed hospital in Piemonte, Italy

Water consumption: 45 m³/day of cold and hot water.

Problem they wanted to solve: Legionella contamination.

Previously use technology: high temperature heated water.

The reasons for choosing Envirolyte technology: as a result of using high temperature technology the damages of the piping line were detected while Legionella contamination still persisted.

Type of the Envirolyte equipment: ELA - 1200.





EnvirolYTE ELA-1200

Installation: Cold and hot water is treated 24/7. Water softener is installed prior to ELA-1200. 90 LPH pump is used for injecting anolyte. Disinfection is controlled via FAC residual.

Below can be seen a schematic of the system layout

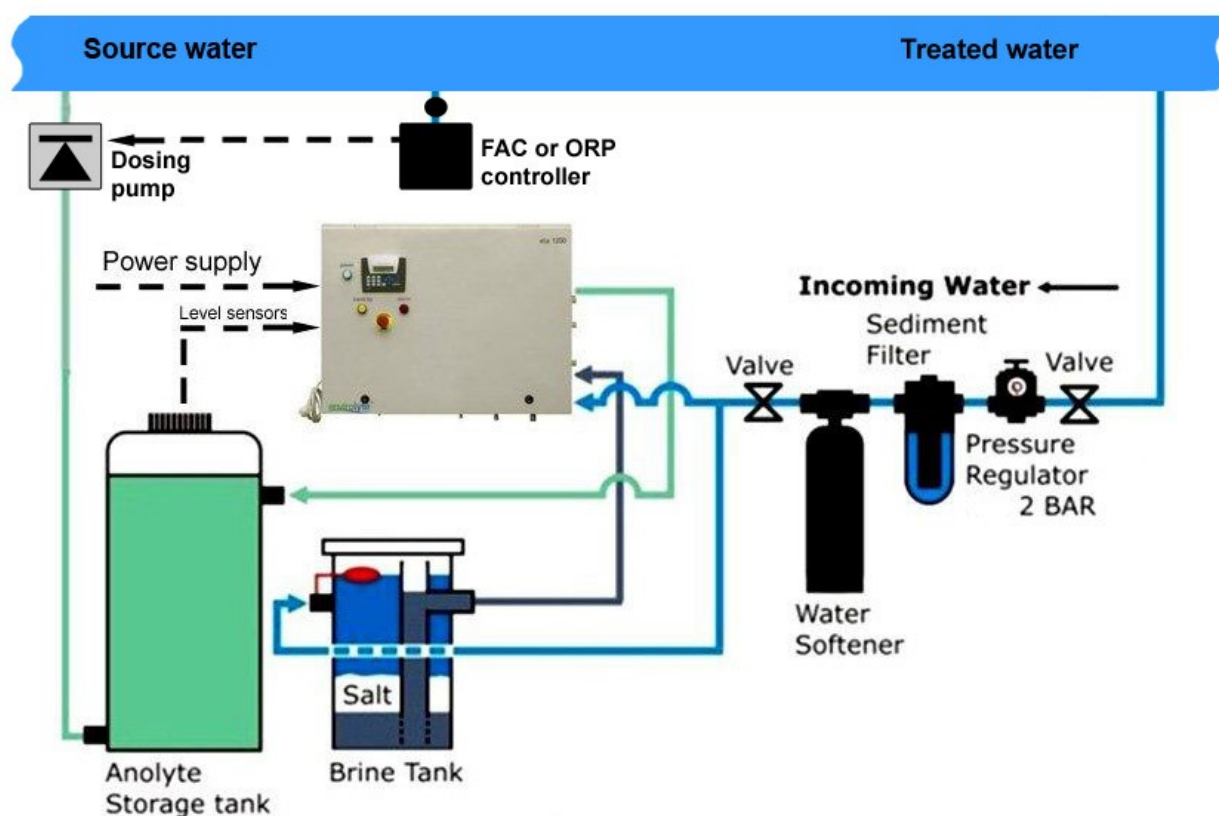

The reported benefits of using Environment water disinfecting technology :

Safety

- no danger of chlorine gas explosion and hazards associated with transportation of any other chlorine based disinfectant;
- no need to mix or dilute hazardous chemicals;
- environmental friendly solution;

Efficiency

- elimination of biofilms and inactivation of pathogenic microorganisms including Legionella species, and nil bacteria counts;
- creates a longer-lasting residual than traditional chlorination, often at a lower dosage
- right dosage, no more no less – corrosion is reduced;
- significant reduction of Trihalomethane and other DBP;

Cost reducing

- Envirolyte system is fully automatic and only requires a minimal operator attention;
- no need for transport, handling or storage of chlorine gas or hypochlorite;
- on site installation in close proximity of urban population;
- anolyte is also used for cleaning/disinfection of hospital surfaces;